

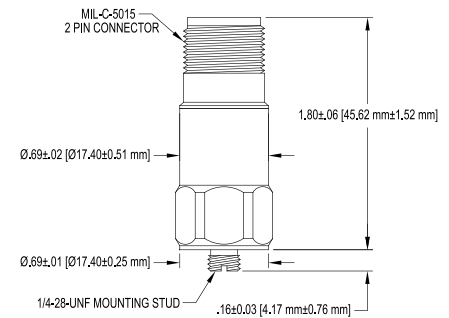

## SPECIFICATIONS

<b>Sensitivity, 25°C:</b>	<b>780B, ±10%</b>	100 mV/g
<b>Acceleration range</b>		80 g peak
<b>Amplitude nonlinearity</b>		1%
<b>Frequency response:</b>	<b>±5%</b>	3 - 5,000 Hz
	<b>±10%</b>	1 - 9,000 Hz
	<b>±3 dB</b>	0.5 - 14,000 Hz
<b>Resonance frequency</b>		30 kHz
<b>Transverse sensitivity, max</b>		5% of axial
<b>Temperature response:</b>	<b>-25°C</b>	-10%
	<b>+120°C</b>	+10%
<b>Power requirement:</b>		
<b>Voltage source</b>		18 - 30 VDC
<b>Current regulating diode</b>		2 - 10 mA
<b>Electrical noise, equiv. g:</b>		
<b>Broadband</b>	<b>2.5 Hz to 25 kHz</b>	700 µg
<b>Spectral</b>	<b>10 Hz</b>	10 µg/√Hz
	<b>100 Hz</b>	5 µg/√Hz
	<b>1,000 Hz</b>	5 µg/√Hz
<b>Output impedance, max</b>		100 Ω
<b>Bias output voltage</b>		12 VDC
<b>Grounding</b>		case isolated, internally shielded
<b>Temperature range</b>		-50° to +120°C
<b>Vibration limit</b>		500 g peak
<b>Shock limit</b>		5,000 g peak
<b>Electromagnetic sensitivity, equiv. g, max</b>		70 µg/gauss
<b>Sealing</b>		hermetic
<b>Base strain sensitivity, max</b>		0.0002 g/µstrain
<b>Sensing element design</b>		PZT, shear
<b>Weight</b>		62 grams
<b>Case material</b>		316 L stainless steel
<b>Mounting</b>		1/4-28 UNF tapped hole
<b>Output connector</b>		2 pin, MIL-C-5015 style
<b>Mating connector</b>		R6 type
<b>Recommended cabling</b>		J10 / J9T2A

**Note:** Frequency response and spectral noise values are typical.

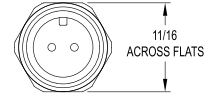

## Connections

Function	Connector pin
power/signal	A
common	B
ground	shell



## Key features

- Compact, lightweight
- Manufactured in ISO 9001 facility

